

Wolfstall 54-56
D-42799 Leichlingen (Germany)
Tel. +49 (0)21 74 799-0
Fax +49 (0)21 74 799799
www.baero.com · E-Mail: info@baero.com

BAERO
PERFECT RETAIL LIGHTING

Montage- und Bedienungsanleitung
Mounting and Operating Instructions
Instructions de montage et d'utilisation
Instrucciones de montaje y mantenimiento
Installazione e istruzioni per l'uso
Инструкция по монтажу и эксплуатации

INTARA-ARONDO NANO
INTARA-BONDO NANO
INTARA-ECONDO NANO



Da unsere Erzeugnisse technischen Veränderungen / Optimierungen unterliegen, übernehmen wir keine Gewähr, dass alle Angaben immer aktualisiert sind. Bei Fragen steht Ihnen selbstverständlich unsere Abteilung Technik unter der Rufnummer +49 (0) 21 74 - 79 90 gerne zur Verfügung.

Sicherheitshinweise für Betrieb und Montage von Leuchten beachten



**Wichtiger Hinweis für Leuchten mit BFL und BBS-Leuchtmitteln:
Bei Flackern, Totalausfall oder sehr gelbem Licht (Lebensdauerende) sofort die Leuchte außer Betrieb setzen und das Leuchtmittel auswechseln.**

- Anschluss darf nur vom Elektriker ausgeführt werden
- Bei Montage örtliche Vorschriften beachten
- Die Leuchten sind anschlussfertig verdrahtet:
 - VDE 0711
 - Schutzklasse I (Schutzleiteranschluss), IP 20
- Angaben auf Polybox und Leuchte sind zu beachten
- Leuchtmittel, Leuchte und Polybox werden im Betrieb heiß
- Leuchte und Polybox nicht mit Dämmmaterial abdecken
- Polyboxen nicht aufeinander legen
- Hochspannung auf Ausgangsseite der Polybox; Lebensgefahr
- Sind Leitungen der Polybox beschädigt, muss die Polybox ausgetauscht werden
- Anschluss Polyboxen Netzseite:
KVG (BFL 35 W, 50 W, 100 W, BBS 35 W, 70 W, 150 W): 230 V +6% -10%, 50 Hz
EVG: 220-240 V, 50/60 Hz
- An einem Stromkreis (mit der Absicherung B16A) dürfen maximal betrieben werden:
 - BFL 35 W, 50 W, 100 W (KVG) 10 Leuchten
 - BFL Mini 50 W (EVG) 24 Leuchten
 - BFL Mini 100 W (EVG) 14 Leuchten
 - BBS 35 / 70 W KVG 10 Leuchten / EVG 14 Leuchten
 - BBS 150 W KVG 7 Leuchten / EVG 6 Leuchten
 - BBS 250 W EVG 9 Leuchten
- Nur bei netzseitig ausgeschalteter Leuchte Leuchtmittel wechseln
- Bei Montage oder Reparatur einer Leuchte ist der Stromkreis abzuschalten
- Der Lampe beigelegte Sicherheitshinweise beachten
- Nach ca. 3 – 5 Minuten erreicht das Leuchtmittel seinen vollen Lichtstrom
- Nach Abschalten oder Netzausfall benötigt das Leuchtmittel eine Abkühlzeit bis zum Wiederzünden. Die Leuchte zum Abkühlen vom Netz trennen.
- Das EVG schaltet bei thermischer Überlastung, bei Lampenausfall und am Lebensdauerende der Lampe ab. Vor der Wiederinbetriebnahme der Leuchte muss das EVG von der Netzspannung getrennt werden. Dies gilt auch für den Lampenwechsel
- Die zulässige Deckenlast beachten
- Abstandshalter auf der Leuchte nicht entfernen oder verändern
- Beschädigte Leitungen der Leuchte dürfen nur durch vom Hersteller gelieferte Leitungen ersetzt werden
- Anschluss nur an geeignete Vorschaltgeräte mit entsprechender Lampenleistung
- BFL Mini-Leuchten (50/100 W) nur mit elektronischem Vorschaltgerät (EVG) betreiben.
- BBS-Leuchten mit beschädigter oder zerbrochener Glasscheibe sind außer Betrieb zu setzen bis die Scheibe ersetzt ist. Die Lampe kann zerplatzen.
- Abstand zur angestrahlten Fläche (Aufkleber im Reflektor)
 - 0,3 m bei BFL 35 / 50 / 100 W
 - 0,5 m bei BBS 35 / 70 W
 - 1,0 m bei BBS 150 W / 250 W
- Nur das für die Leuchte zugelassene Leuchtmittel verwenden. Aufkleber im Reflektor oder Typenschild beachten
- Hinweis für 3-Phasen-Betrieb:
Vor und während Betrieb sicherstellen, dass der Neutralleiter an allen EVG-Leuchten ordnungsgemäß angeschlossen ist.
- An Leuchten, Lichtrohren und Trägersystemen nichts anbringen, zum Beispiel Preistafeln, Deko-Elemente.

KVG: Konventionelles Vorschaltgerät

EVG: Elektronisches Vorschaltgerät

Montage- und Bedienungsanleitung

INTARA-ARONDO NANO – INTARA-BONDO NANO – INTARA-ECONDO NANO

Leuchtentyp

Lichtquelle Art.-Nr.

INTARA-ARONDO NANO

INTARA-ARONDO NANO-MBFL	BFL Mini 50 W – 3320
INTARA-ARONDO NANO-MBFL	BFL Mini 100 W – 3321
INTARA-ARONDO NANO-BBS	BBS 70 W – 3318
INTARA-ARONDO NANO-BBS	BBS 150 W – 3319

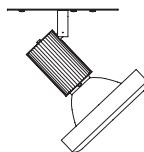

INTARA-BONDO NANO

INTARA-BONDO NANO-MBFL	BFL Mini 50 W – 3320
INTARA-BONDO NANO-MBFL	BFL Mini 100 W – 3321
INTARA-BONDO NANO-BBS	BBS 70 W – 3318
INTARA-BONDO NANO-BBS	BBS 150 W – 3319

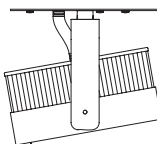
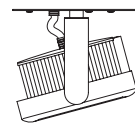

INTARA-ECONDO NANO

INTARA-ECONDO BASIC NANO-MBFL	BFL Mini 50 W – 3320
INTARA-ECONDO BASIC NANO-MBFL	BFL Mini 100 W – 3321
INTARA-ECONDO BASIC NANO-BBS	BBS 70 W – 3318
INTARA-ECONDO BASIC NANO-BBS	BBS 150 W – 3319

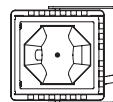

INTARA-ECONDO BWNANO-MBFL	BFL Mini 100 W – 3321
INTARA-ECONDO BWNANO-BBS	BBS 70 W – 3318
INTARA-ECONDO BWNANO-BBS	BBS 150 W – 3319

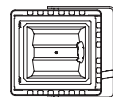

INTARA-ECONDO WWNANO-MBFL	BFL Mini 50 W – 3320
INTARA-ECONDO WWNANO-MBFL	BFL Mini 100 W – 3321
INTARA-ECONDO WWNANO-BBS	BBS 70 W – 3318
INTARA-ECONDO WWNANO-BBS	BBS 150 W – 3319

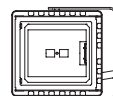

INTARA-ECONDO WALL NANO-MBFL	BFL Mini 50 W – 3320
INTARA-ECONDO WALL NANO-MBFL	BFL Mini 100 W – 3321
INTARA-ECONDO WALL NANO-BBS	BBS 70 W – 3318
INTARA-ECONDO WALL NANO-BBS	BBS 150 W – 3319

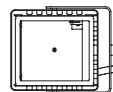

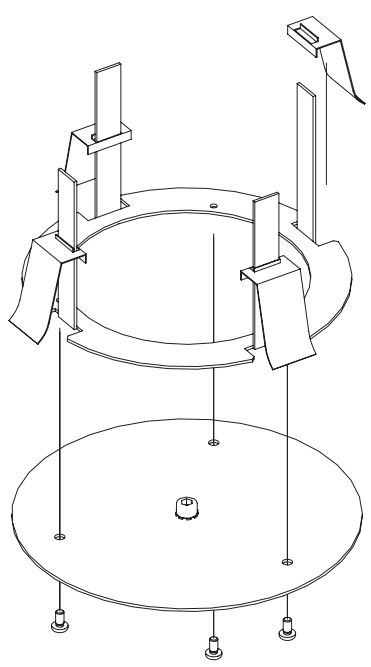
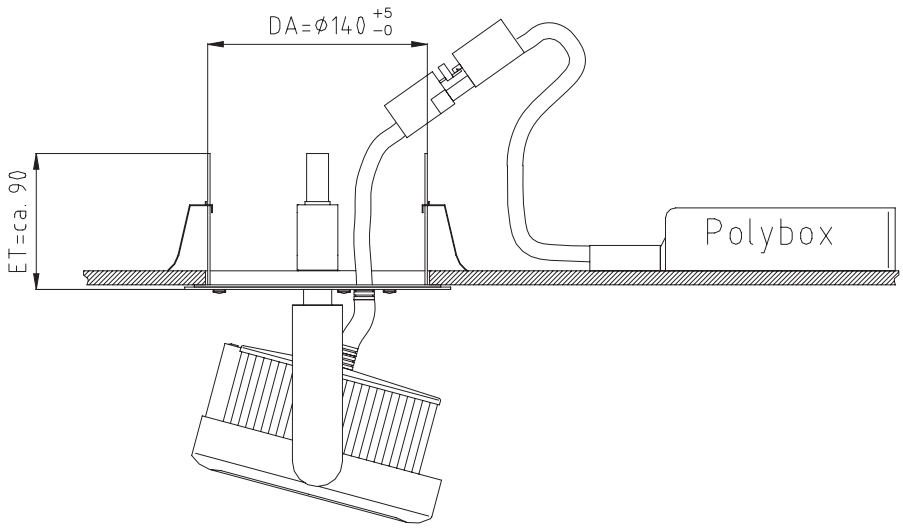

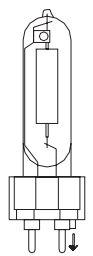
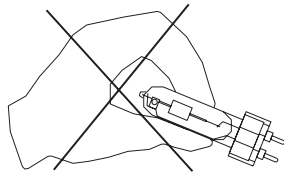

BFL Mini

INTARA-ARONDO NANO

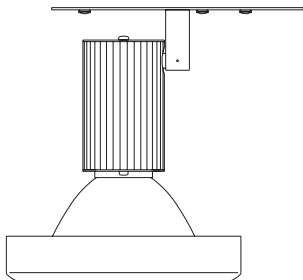

INTARA-BONDO NANO

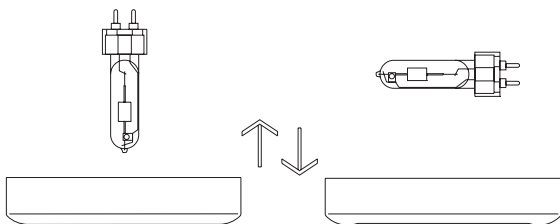
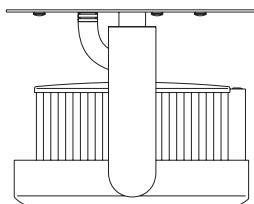

INTARA-ECONDO NANO

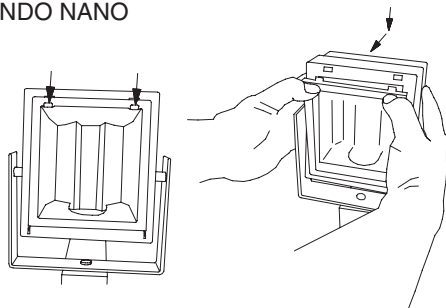

INTARA-ECONDO NANO mit Batwing-Reflektor



Lampe quer zur beleuchteten Fläche

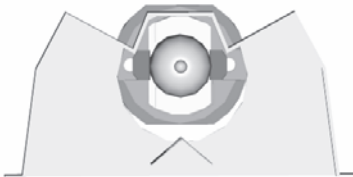
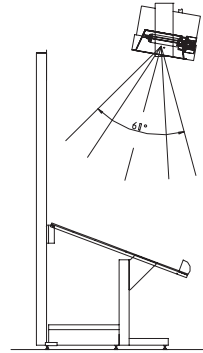
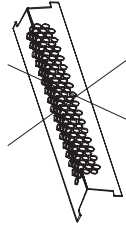
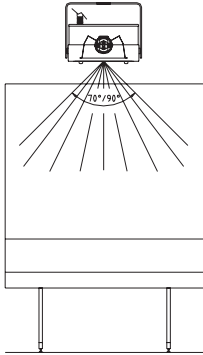

Lampe längs in Gang- und Regalrichtung

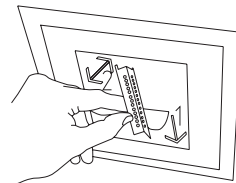
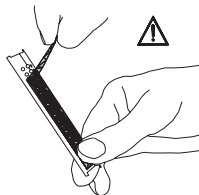
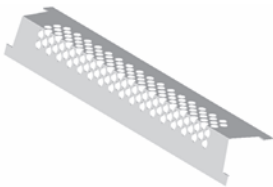
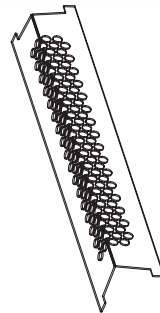
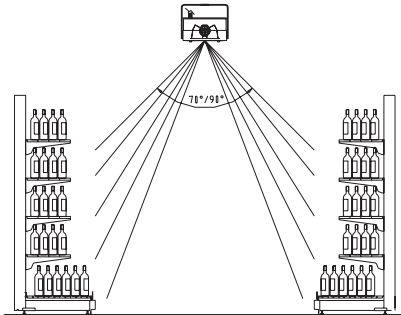

As our products are subject to technical modifications, we cannot guarantee, that all information is always up to date.

Please contact our technical department on +49 (0) 21 74 - 79 90 with any queries.

Observe safety information for operating and installing lighting fixtures.



Important information for fixtures with BFL and BBS lamps:

When the light flickers or there is a total loss of power or very yellow light (signifying end of life), the fixture should be switched off immediately and the lamp replaced

- The fixtures must only be connected by a fully qualified electrician
- Observe all safety regulations when assembling
- The fixtures are wired up ready for connection:
 - VDE 0711
 - Protection class I (protective earth connection), IP 20
- Information provided on the Polybox and fixtures must be followed
- Lamps, Fixtures and the Polybox become hot during use
- Do not put polyboxes on top of each other
- Do not cover the Fixtures or Polybox with insulating material
- DANGER OF DEATH: High voltages are present at the output of the Polybox
- The Polybox must be replaced if its cables are damaged
- Polybox mains connections:
 - Conventional ballast (BFL 35, W, 50 W, 100 W, BBS 35 W, 70 W, 150 W): 230V +6% -10%, 50 Hz
 - Electronic ballast: 220-240 V, 50/60 Hz
- The following maximum number of fixtures may be operated in a circuit (with a B16A fuse):
- BFL 35 W, 50 W, 100 W (conventional ballast) 10 fixtures
- BFL Mini 50 W (electronic ballast) 24 fixtures
- BFL Mini 100 W (electronic ballast) 14 fixtures
- BBS 35 / 70 W (conventional ballast) 10 fixtures / electronic ballast 14 fixtures
- BBS 150 W (conventional ballast) 7 fixtures / electronic ballast 6 fixtures
- BBS 250 W EVG 9 fixtures
- Only change lamps when mains power is disconnected
- Observe the safety instructions included with the fixtures
- The current in the fixture rises to its maximum within approx. 3 to 5 minutes
- After being switched off, or following a mains failure, the lamp must cool down before being restarted. Disconnect the power from the fixture to allow it to cool down.
- The electronic ballast is fitted with an internal overload. The ballast must be briefly disconnected from the mains supply for the overload to reset.
- The electronic ballast switches off in the event of thermal overload, when the lamp fails and when the lamp reaches the end of its life. Before the fixture is put into operation again the electronic ballast must be disconnected from the power supply. This also applies when lamps are replaced
- Do not remove or modify the fixtures spacers
- If any of the internal wires of the fixture are damaged they must only be replaced by wires supplied by the manufacturer
- Only connect to suitable ballast matching the fixture power
- BFL Mini-fixtures (50/100 W) are only for operation with an electronic ballast
- When the glass filter is damaged or broken in a BBS fixture, the fixture must not be operated until the filter is replaced, because the lamp could explode.
- Minimum distance to irradiated surface (adhesive label in reflector)
 - 0.3 m for BFL 35 / 50 / 100 W
 - 0.5 m for BBS 35 / 70 W
 - 1.0 m for BBS 150 W / 250 W
- Only use the lamp that is approved for the fixture. Observe the instructions on the adhesive label in the reflector or the type plate
- Information for 3-phase operation:
 - Before and during operation ensure that the neutral wire is properly connected on all fixtures with electronic ballasts
- Do not attach anything to fixtures, light tubes and support systems, for example price boards or decorations.

Mounting and Operating Instructions

INTARA-ARONDO NANO – INTARA-BONDO NANO – INTARA-ECONDO NANO

Fixture model

Light source Art. no.

INTARA-ARONDO NANO

INTARA-ARONDONANO-MBFL	BFL Mini 50 W – 3320
INTARA-ARONDONANO-MBFL	BFL Mini 100 W – 3321
INTARA-ARONDONANO-BBS	BBS 70 W – 3318
INTARA-ARONDONANO-BBS	BBS 150 W – 3319

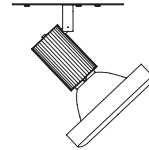

INTARA-BONDO NANO

INTARA-BONDONANO-MBFL	BFL Mini 50 W – 3320
INTARA-BONDONANO-MBFL	BFL Mini 100 W – 3321
INTARA-BONDONANO-BBS	BBS 70 W – 3318
INTARA-BONDONANO-BBS	BBS 150 W – 3319

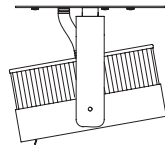
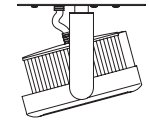

INTARA-ECONDO NANO

INTARA-ECONDOBASICNANO-MBFL	BFL Mini 50 W – 3320
INTARA-ECONDOBASICNANO-MBFL	BFL Mini 100 W – 3321
INTARA-ECONDOBASICNANO-BBS	BBS 70 W – 3318
INTARA-ECONDOBASICNANO-BBS	BBS 150 W – 3319

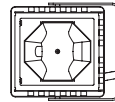

INTARA-ECONDOBWNANO-MBFL	BFL Mini 100 W – 3321
INTARA-ECONDOBWNANO-BBS	BBS 70 W – 3318
INTARA-ECONDOBWNANO-BBS	BBS 150 W – 3319

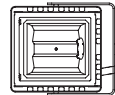

INTARA-ECONDOWWNANO-MBFL	BFL Mini 50 W – 3320
INTARA-ECONDOWWNANO-MBFL	BFL Mini 100 W – 3321
INTARA-ECONDOWWNANO-BBS	BBS 70 W – 3318
INTARA-ECONDOWWNANO-BBS	BBS 150 W – 3319

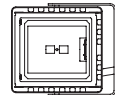

INTARA-ECONDOWALLNANO-MBFL	BFL Mini 50 W – 3320
INTARA-ECONDOWALLNANO-MBFL	BFL Mini 100 W – 3321
INTARA-ECONDOWALLNANO-BBS	BBS 70 W – 3318
INTARA-ECONDOWALLNANO-BBS	BBS 150 W – 3319

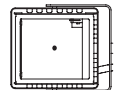

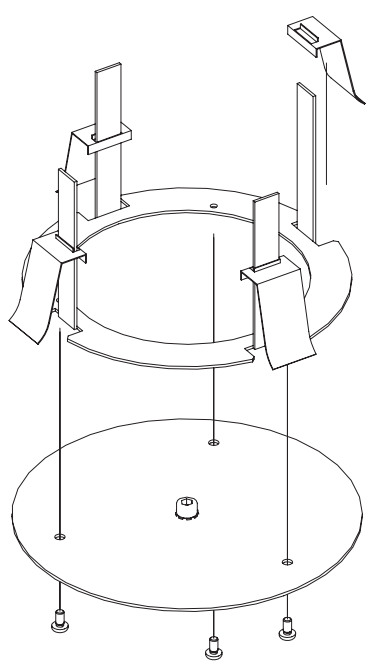
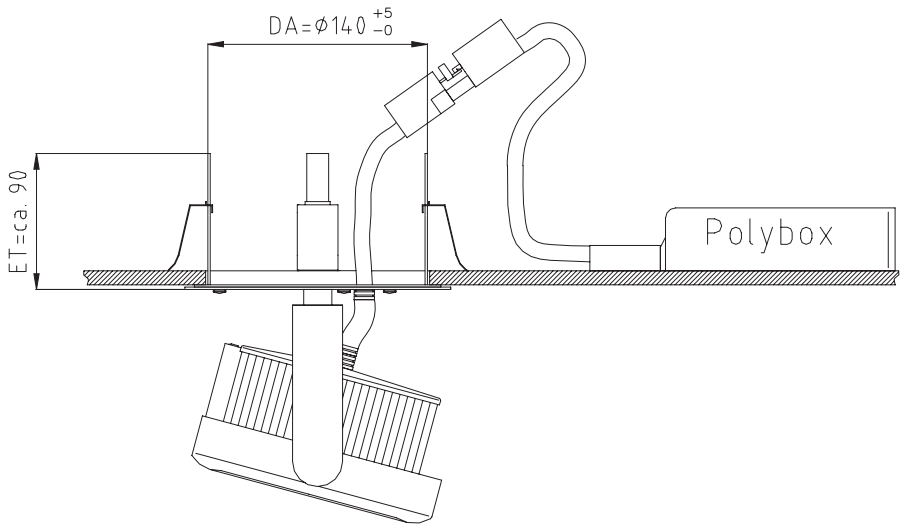

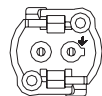
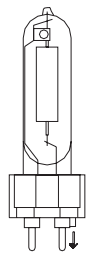
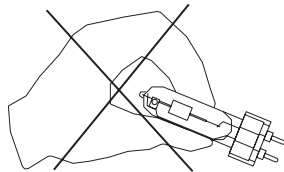

BFL Mini

INTARA-ARONDO NANO

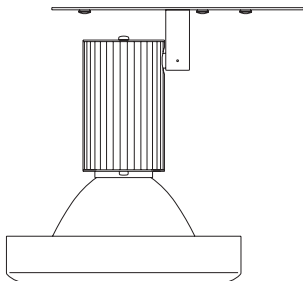

INTARA-BONDO NANO

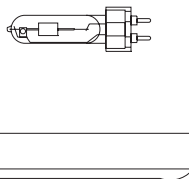
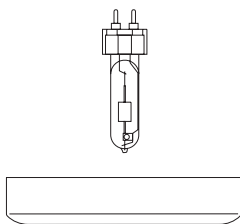
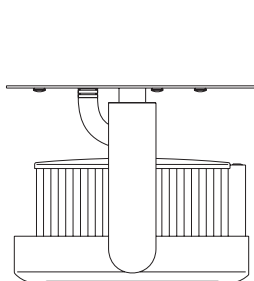

INTARA-ECONDO NANO

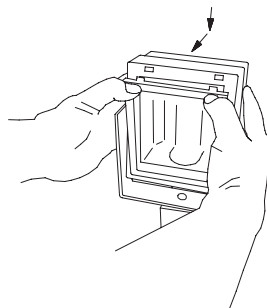
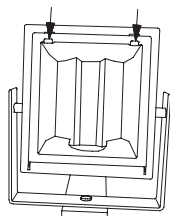

INTARA-ECONDO NANO



INTARA-ECONDO NANO with Batwing-Reflector

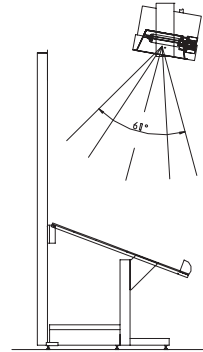
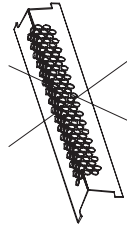
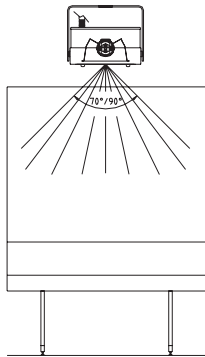

Lamp at right angle to surface to be illuminated

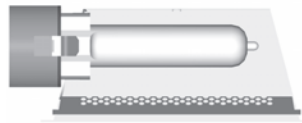

Lamp lengthwise in the direction of the aisle and shelf

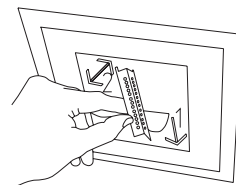
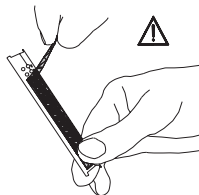
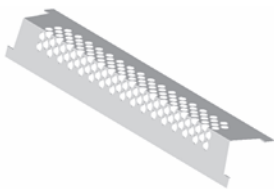
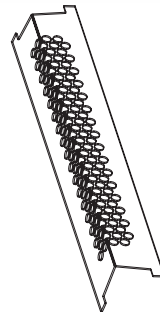
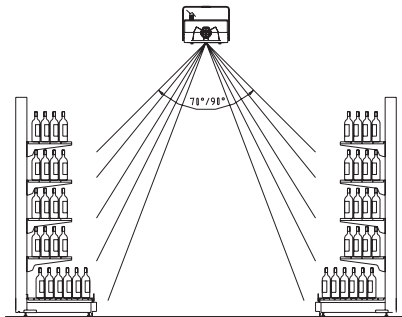

Nos produits sont susceptibles d'être modifiés techniquement à tout moment. Nous ne pouvons de ce fait garantir que toutes les informations de cette fiche technique soient à jour.

Notre service technique se tient à votre entière disposition pour toute information. +49 (0) 21 74 - 79 90

Se conformer aux consignes de sécurité pour l'exploitation et le montage de luminaires.



Remarque importante pour les luminaires équipés d'ampoules BFL et BBS :

Lors d'un vacillement de la lumière, d'un arrêt total ou lorsque la lumière devient très jaune (fin de la durée d'existence), éteindre immédiatement les luminaires et remplacer l'ampoule.

- Le raccordement doit être effectué par un électricien
- Lors du montage, respecter les consignes de sécurité spécifiques
- Les luminaires sont câblés pour raccordement
 - VDE 0711
 - Classe de protection I (conducteur de protection), IP 20
- Respecter les données figurant sur le Polybox et le luminaire
- Lors du fonctionnement, les lampes, luminaires et Polybox chauffent
- Ne pas couvrir les luminaires et les Polybox avec du matériau isolant
- Ne pas poser les platines de commande l'une sur l'autre
- Haute tension à la sortie du Polybox; danger de mort
- Si les câbles du Polybox sont endommagés, échanger le Polybox
- Raccordement du Polybox au réseau:
ballast conventionnel (BFL 35 W, 50 W, 100 W, BBS 35 W, 70 W, 150 W): 230 V +6% -10%, 50 Hz
ballast électronique: 220-240 V, 50/60 Hz
- Ne faire fonctionner sur un circuit (avec la protection par fusible B16A) qu'au maximum :
 - BFL 35 W, 50 W, 100 W (ballast conventionnel) 10 luminaires
 - BFL Mini 50 W (ballast électronique) 24 luminaires
 - BFL Mini 100 W (ballast électronique) 14 luminaires
 - BBS 35 / 70 W (ballast conventionnel) 10 luminaires /
ballast électronique 14 luminaires
 - BBS 150 W (ballast conventionnel) 7 luminaires /
ballast électronique 6 luminaires
 - BBS 250 W EVG 9 luminaires
- Ne remplacer la lampe qu'avec un luminaire hors tension
- Observer les consignes de sécurité accompagnant la lampe
- La lampe atteint son flux lumineux maximal après 3 à 5 minutes
- Après avoir éteint ou en cas de panne de secteur, la lampe doit refroidir avant un rallumage.
Déconnecter le luminaire pendant le refroidissement
- Couper momentanément le bloc d'alimentation électronique du réseau après avoir déclencher le dispositif de sécurité.
- Le ballast électronique s'éteint en cas de surcharge thermique ou si la lampe lâche ou si la lampe atteint sa fin de vie. Avant toute remise en service de l'installation, le ballast électronique doit être coupé de l'alimentation. Il en est de même pour le remplacement de lampes
- Ne pas enlever ou modifier la protection du luminaire
- Les câbles endommagés du luminaire ne peuvent être remplacés que par des câbles fournis par le fabricant
- Raccordement exclusivement au ballast adéquat avec puissance de lampe correspondante
- Utiliser les lampes BFL Mini (50/100 W) uniquement avec des Polybox électroniques
- Les luminaires avec filtre endommagé ou cassé seront mis hors service jusqu'au remplacement de celui-ci. La lampe peut exploser
- Distance par rapport à la surface éclairée (étiquette sur réflecteur)
 - 0,3 m pour BFL 35 / 50 / 100 W
 - 0,5 m pour BBS 35 / 70 W
 - 1,0 m pour BBS 150 W / 250 W
- N'utiliser que des lampes correspondant au luminaire. Observer l'étiquette sur le réflecteur ou la plaque d'identification
- Remarque pour le fonctionnement triphasé :
Vérifier avant et pendant l'utilisation que le conducteur neutre est raccordé en bonne et due forme à tous les luminaires à bloc d'alimentation électronique.
- Ne rien attacher d'aucune manière sur les luminaires, structures et supports comme par exemple tableaux de prix ou décorations.

Intructions de montage et d'utilisation

INTARA-ARONDO NANO – INTARA-BONDO NANO – INTARA-ECONDO NANO

Type de luminaire	Source lumineuse	Article no.
-------------------	------------------	-------------

INTARA-ARONDO NANO

INTARA-ARONDO NANO-MBFL	BFL Mini 50 W	– 3320
INTARA-ARONDO NANO-MBFL	BFL Mini 100 W	– 3321
INTARA-ARONDO NANO-BBS	BBS 70 W	– 3318
INTARA-ARONDO NANO-BBS	BBS 150 W	– 3319

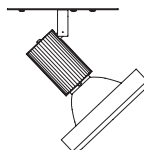

INTARA-BONDO NANO

INTARA-BONDO NANO-MBFL	BFL Mini 50 W	– 3320
INTARA-BONDO NANO-MBFL	BFL Mini 100 W	– 3321
INTARA-BONDO NANO-BBS	BBS 70 W	– 3318
INTARA-BONDO NANO-BBS	BBS 150 W	– 3319

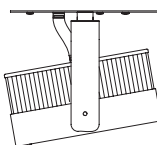
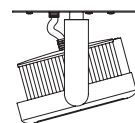

INTARA-ECONDO NANO

INTARA-ECONDO BASIC NANO-MBFL	BFL Mini 50 W	– 3320
INTARA-ECONDO BASIC NANO-MBFL	BFL Mini 100 W	– 3321
INTARA-ECONDO BASIC NANO-BBS	BBS 70 W	– 3318
INTARA-ECONDO BASIC NANO-BBS	BBS 150 W	– 3319

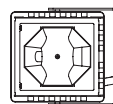

INTARA-ECONDO BWNANO-MBFL	BFL Mini 100 W	– 3321
INTARA-ECONDO BWNANO-BBS	BBS 70 W	– 3318
INTARA-ECONDO BWNANO-BBS	BBS 150 W	– 3319

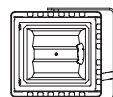

INTARA-ECONDO WWNANO-MBFL	BFL Mini 50 W	– 3320
INTARA-ECONDO WWNANO-MBFL	BFL Mini 100 W	– 3321
INTARA-ECONDO WWNANO-BBS	BBS 70 W	– 3318
INTARA-ECONDO WWNANO-BBS	BBS 150 W	– 3319

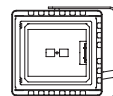

INTARA-ECONDO WALL NANO-MBFL	BFL Mini 50 W	– 3320
INTARA-ECONDO WALL NANO-MBFL	BFL Mini 100 W	– 3321
INTARA-ECONDO WALL NANO-BBS	BBS 70 W	– 3318
INTARA-ECONDO WALL NANO-BBS	BBS 150 W	– 3319

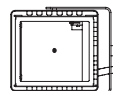

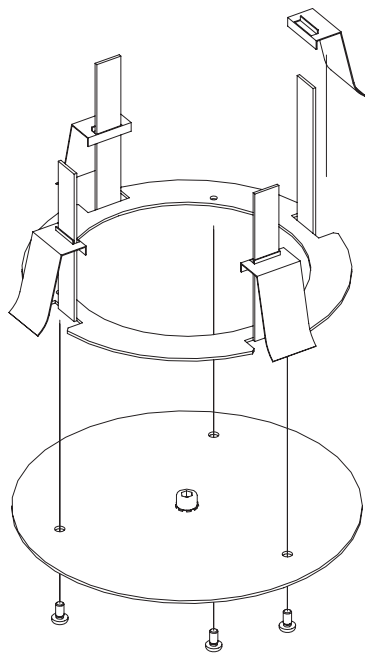
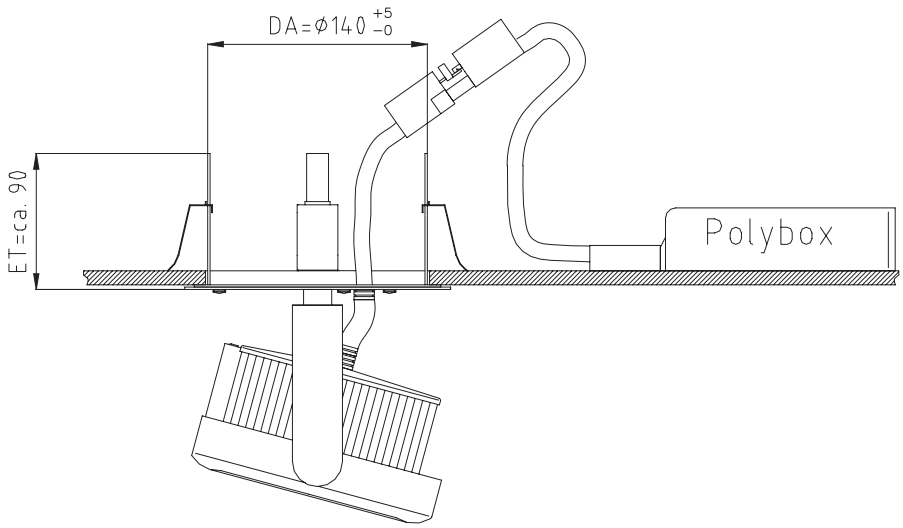

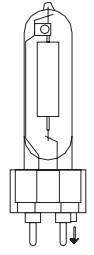
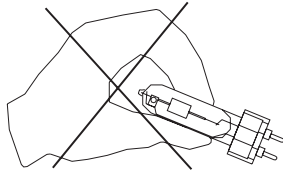

BFL Mini

INTARA-ARONDO NANO

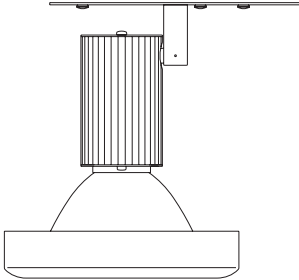

INTARA-BONDO NANO

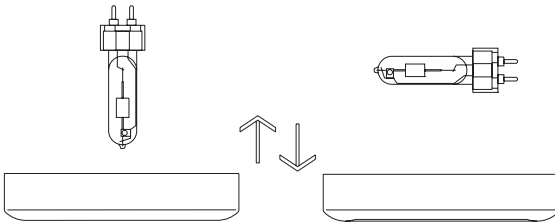
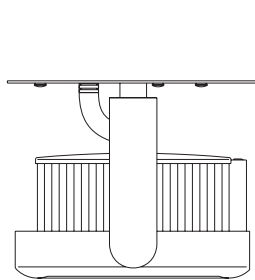

INTARA-ECONDO NANO

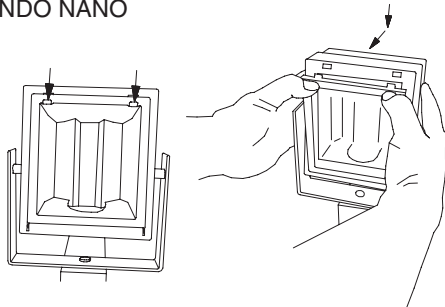

INTARA-ECONDO NANO



INTARA-ECONDO NANO pour Réflecteur Batwing

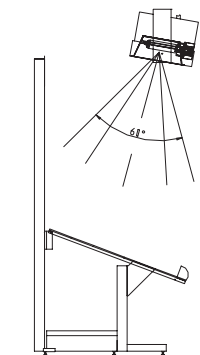
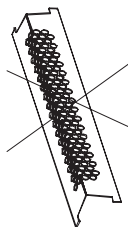
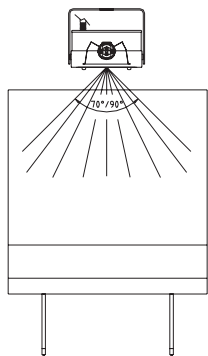

Lampe montée de manière perpendiculaire à la surface à éclairer

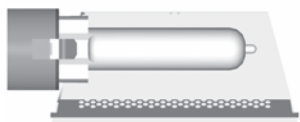
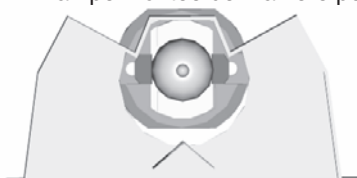

Lampe montée dans l'axe du couloir et des rayons

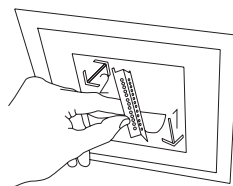
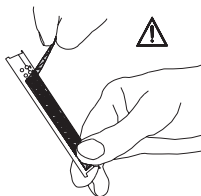
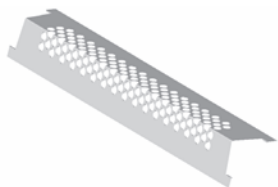
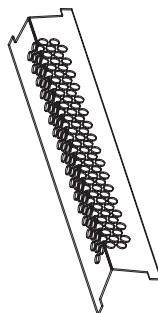
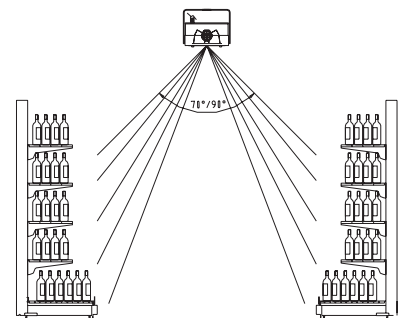

Nuestros productos están sujetos a cambios técnicos u optimizaciones por ello no nos responsabilizamos que toda la información técnica este actualizada. En caso de preguntas, no vacile en llamar a nuestro Dpto. Técnico bajo el número de teléfono +49 (0) 21 74 - 79 90.

Obsérvense las advertencias de seguridad durante la operación y el montaje de las luminarias.



Información importante para luminarias con lámpara BFL y BBS:

En caso de que la lámpara parpadee, pierda totalmente su potencia o dé una luz muy amarilla (final de la vida lámpara), des conectar la luminaria enseguida de la red y sustituir la lámpara.

- La conexión sólo debe ser realizada por un electricista
- Cumpla las disposiciones locales durante el montaje
- Las lámparas se entregan con los cables listos para su conexión:
 - VDE 0711
 - Clase de protección I (Conexión del conductor protector), IP 20
- Tenga en cuenta los datos que figuran en la Polybox y en la luminaria
- La lámpara, la luminaria y la Polybox se calientan cuando están en funcionamiento
- No cubra la luminaria ni la Polybox con material aislante-
- No desmontar el equipo electrónico
- Alta tensión en la salida de la Polybox: Peligro de muerte
- Si los cables de la Polybox están dañados, reemplace esta última
- Conexión de las Polybox, lado de la red:
 - equipo convencional (BFL 35 W, 50 W, 100 W, BBS 35 W, 70 W, 150 W):
230 V +6% -10%, 50Hz
 - equipo electrónico: 220-240 V, 50/60 Hz
- En un circuito (con protección por fusible B16A) pueden conectarse como máximo:
 - BFL 35 W, 50 W, 100 W (equipo convencional): 10 luminarias
 - BFL Mini 50 W (equipo electrónico): 24 luminarias
 - BFL Mini 100 W (equipo electrónico): 14 luminarias
 - BBS 35 / 70 W (equipo convencional): 10 luminarias / equipo electrónico: 14 luminarias
 - BBS 150 W (equipo convencional): 7 luminarias / equipo electrónico: 6 luminarias
 - BBS 250 W EVG 9 luminarias
- Sólo cambie las lámparas con la luminaria desconectada de la red
- Cumpla las instrucciones de seguridad adjuntas a la luminaria
- La lámpara alcanza su pleno flujo luminoso transcurridos entre 3 y 5 minutos.
- Después del apagado o de un corte de corriente, la lámpara requiere un período de enfriamiento para volver a encenderse. Desconecte la luminaria de la red para que se enfríe.
- El equipo electrónico ha de ser desconectado de la red una vez halla funcionado el circuito interno de seguridad
- El equipo electrónico se desconecta en caso de sobrecarga térmica, fallo de una de las bombillas y al término de la vida útil de las mismas. Antes de activar de nuevo la lámpara deberá desconectarse de la red el equipo electrónico. Lo mismo debe tenerse en cuenta al efectuar un cambio de bombillas
- No retire ni modifique los espaciadores de la luminaria
- Sustituya los cables dañados de la luminaria únicamente por cables originales del fabricante
- Realice la conexión únicamente a equipos de la capacidad adecuada
- Luminarias BFL Mini (50/100 W) solo funcionan con equipos electrónicos
- No utilice luminarias con cristales dañados o rotos hasta sustituirlos. La lámpara puede explotar.
- Distancia mínima a la superficie irradiada (Etiqueta en el reflector)
 - 0,3 m con BFL 35 / 50 / 100 W
 - 0,5 m con BBS 35 / 70 W
 - 1,0 m con BBS 150 W / 250 W
- Utilice únicamente las lámparas autorizadas para la luminaria. Consulte la etiqueta colocada sobre el reflector o la placa de tipo.
- Información para el uso en tres fases:
 - Antes y durante el uso asegurarse que el neutro este conectado a todos los equipos según la normativa.
- No colgar ni apoyar elementos extraños de las luminarias ni de los sistemas suspendidos.

Instrucciones de montaje y mantenimiento

INTARA-ARONDO NANO – INTARA-BONDO NANO – INTARA-ECONDO NANO

Tipo de luminaria	Tipo de lámpara	Nº de ref.
-------------------	-----------------	------------

INTARA-ARONDO NANO

INTARA-ARONDONANO-MBFL	BFL Mini	50 W – 3320
INTARA-ARONDONANO-MBFL	BFL Mini	100 W – 3321
INTARA-ARONDONANO-BBS	BBS	70 W – 3318
INTARA-ARONDONANO-BBS	BBS	150 W – 3319

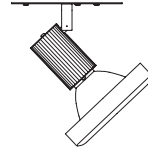

INTARA-BONDO NANO

INTARA-BONDONANO-MBFL	BFL Mini	50 W – 3320
INTARA-BONDONANO-MBFL	BFL Mini	100 W – 3321
INTARA-BONDONANO-BBS	BBS	70 W – 3318
INTARA-BONDONANO-BBS	BBS	150 W – 3319

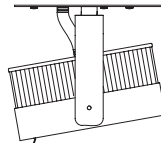
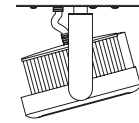

INTARA-ECONDO NANO

INTARA-ECONDOBASICNANO-MBFL	BFL Mini	50 W – 3320
INTARA-ECONDOBASICNANO-MBFL	BFL Mini	100 W – 3321
INTARA-ECONDOBASICNANO-BBS	BBS	70 W – 3318
INTARA-ECONDOBASICNANO-BBS	BBS	150 W – 3319

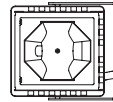

INTARA-ECONDOBWNANO-MBFL	BFL Mini	100 W – 3321
INTARA-ECONDOBWNANO-BBS	BBS	70 W – 3318
INTARA-ECONDOBWNANO-BBS	BBS	150 W – 3319

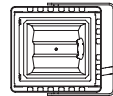

INTARA-ECONDOWWNANO-MBFL	BFL Mini	50 W – 3320
INTARA-ECONDOWWNANO-MBFL	BFL Mini	100 W – 3321
INTARA-ECONDOWWNANO-BBS	BBS	70 W – 3318
INTARA-ECONDOWWNANO-BBS	BBS	150 W – 3319

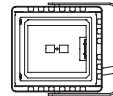

INTARA-ECONDOWALLNANO-MBFL	BFL Mini	50 W – 3320
INTARA-ECONDOWALLNANO-MBFL	BFL Mini	100 W – 3321
INTARA-ECONDOWALLNANO-BBS	BBS	70 W – 3318
INTARA-ECONDOWALLNANO-BBS	BBS	150 W – 3319

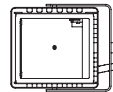

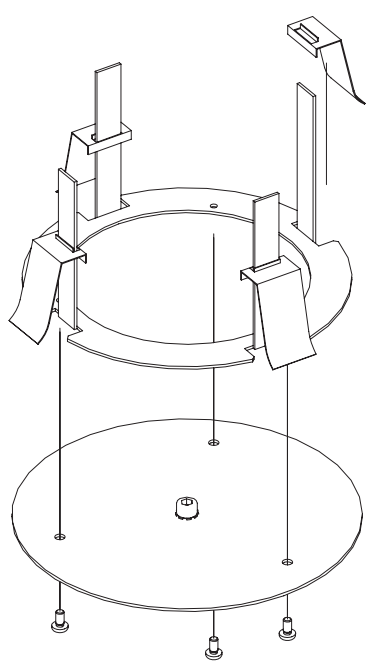
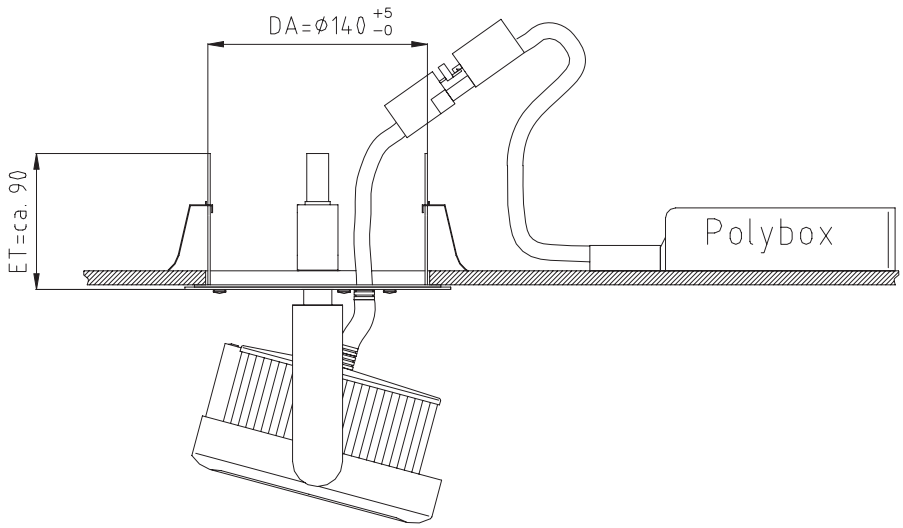

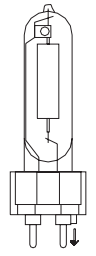
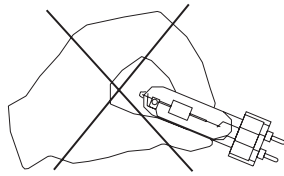

BFL Mini

INTARA-ARONDO NANO

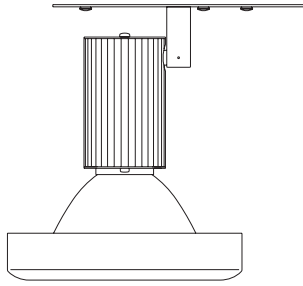

INTARA-BONDO NANO

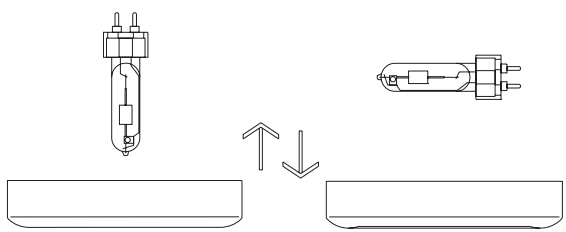
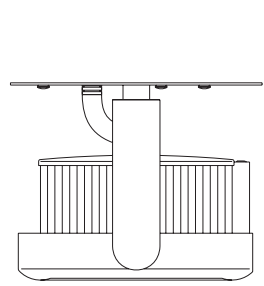

INTARA-ECONDO NANO

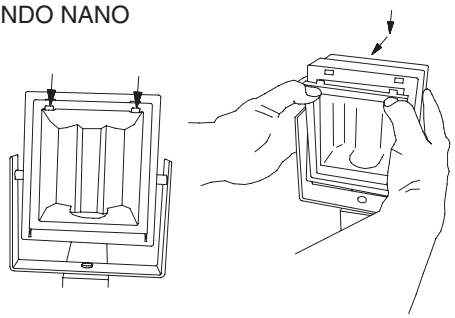

INTARA-ECONDO NANO



INTARA-ECONDO NANO Riflettore Batwing

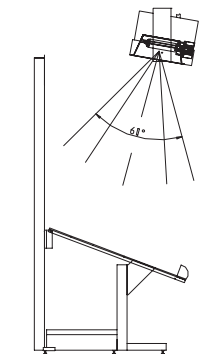
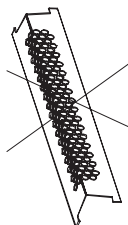
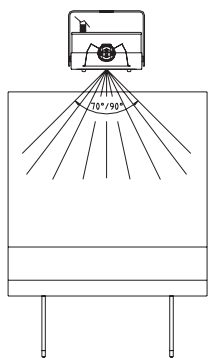

Lámpara transversalmente a la superficie iluminada

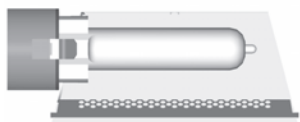
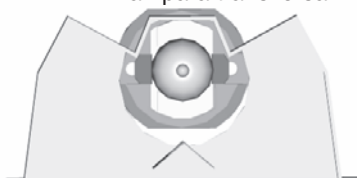

Lámpara longitudinalmente en dirección del pasillo y del estante

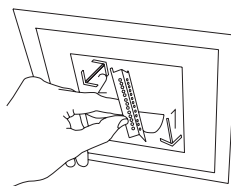
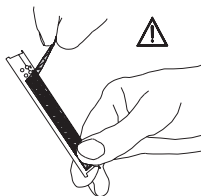
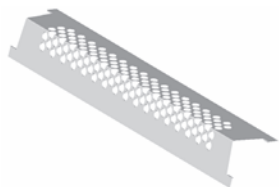
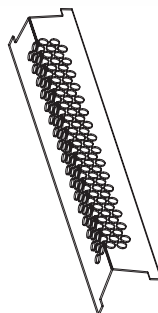
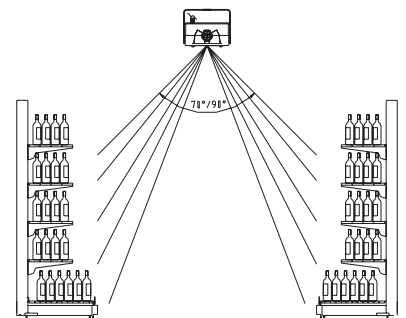

I nostri prodotti sono soggetti a modifiche / migliorie tecniche costanti e pertanto non possiamo garantire che tutti i dati forniti siano stati aggiornati. Il nostro Ufficio Tecnico - raggiungibile al numero di telefono +49 (0) 21 74 - 79 90 è a Vostra disposizione per eventuali domande in merito.

Osservare le avvertenze per la sicurezza durante il funzionamento ed il montaggio dei fari



Nota importante per fari dotati di lampade BFL e BSL: in caso di sfarfallamenti, spegnimento improvviso o luce molto giallastra (termine ciclo di vita) spegnere immediatamente il faro e sostituire la lampada.

- L'allacciamento deve essere effettuato solo da un elettricista
- Durante il montaggio osservare le norme locali
- I fari sono pronti per l'allacciamento e dotati di cavi:
 - VDE 0711
 - Classe di protezione I (collegamento a massa), IP 20
- Osservare le indicazioni riportate sul polybox e sul faro
- Durante il funzionamento la lampada, il faro e il polybox si surriscaldano
- Non posizionare i polybox a distanza l'uno dall'altro
- Dal polybox esce dell'alta tensione; pericolo di morte
- Se i cavi del polybox sono danneggiati bisogna sostituire il polybox
- Allacciamento dei polybox, lato rete:
KVG (BFL 50 W, 100 W, BBS 35 W, 70 W, 150 W): 230 V +6% -10%, 50 Hz
EVG: 220-240 V, 50/60 Hz
- Su un circuito elettrico (con il fusibile B16A) possono operare al massimo:
 - BFL 35 W, 50 W, 100 W (KVG) 10 fari
 - BFL Mini 50 W (EVG) 24 fari
 - BFL Mini 100 W (EVG) 14 fari
 - BBS 35 / 70 W (KVG) 10 fari/ EVG 14 fari
 - BBS 150 W (KVG) 7 fari/ EVG 6 fari
 - BBS 250 W EVG 9 fari
- Sostituire le lampade solo quando i fari non sono più allacciati alla rete elettrica
- Osservare le indicazioni sulla sicurezza contenute nella confezione del faro
- La lampada raggiunge il pieno flusso luminoso dopo ca. 3-5 minuti
- Dopo lo spegnimento o interruzione dell'erogazione di corrente la lampada richiede un periodo di raffreddamento prima di poter accendere nuovamente il faro. Per il raffreddamento staccare il faro dalla rete elettrica.
- Dopo che è scattato il fusibile interno bisogna separare per breve tempo l'unità ausiliaria elettronica dall'alimentazione di corrente
- L'alimentatore elettronico si disattiva in caso di sovraccarico termico, spegnimento delle lampade e al termine della durata di vita delle lampade. Prima di riaccendere il faro staccare l'alimentatore dalla tensione di rete. Procedere allo stesso modo anche in caso di sostituzione delle lampade
- Non rimuovere o spostare il distanziatore sul faro
- Eventuali cavi danneggiati del faro possono essere sostituiti solo con cavi forniti dal produttore.
- Allacciare solo ad un ballast adatto con potenza corrispondente a quella del faro.
- Far funzionare le lampade mini BFL (50/100 W) solo con ballast elettronico (EVG)
- I fari con copertura anteriore in vetro danneggiata o rotta devono essere spenti e tenuti spenti fino alla sostituzione della copertura. La lampada potrebbe scoppiare.
- Distanza dalla superficie illuminata (vedere etichetta nel riflettore)
 - 0,3 m per lampade BFL 35 / 50 / 100 W
 - 0,5 m per lampade BBS 35 / 70 W
 - 1,0 m per lampade BBS 150 W / 250 W
- Utilizzare solo lampade omologate per questo tipo di fari. Vedere l'etichetta nel riflettore o la targhetta con il tipo di modello
- Nota per il funzionamento trifase: prima e durante il funzionamento assicurarsi che il conduttore neutro sia allacciato correttamente a tutte le unità ausiliarie elettroniche (polybox) dei fari.
- Non applicare nulla, p.e. tabelle con i prezzi, elementi decorativi ecc., su fari, strutture tubolari e sistemi portanti.

KVG: Ballast tradizionale (elettromeccanico)

EVG: Ballast elettronico

Installazione e istruzioni per l'uso

INTARA-ARONDO NANO – INTARA-BONDO NANO – INTARA-ECONDO NANO

Modello lampada	Componenti luminoso	No. Articolo
-----------------	---------------------	--------------

INTARA-ARONDO NANO

INTARA-ARONDONANO-MBFL	BFL Mini 50 W	– 3320
INTARA-ARONDONANO-MBFL	BFL Mini 100 W	– 3321
INTARA-ARONDONANO-BBS	BBS 70 W	– 3318
INTARA-ARONDONANO-BBS	BBS 150 W	– 3319

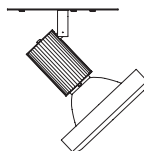

INTARA-BONDO NANO

INTARA-BONDONANO-MBFL	BFL Mini 50 W	– 3320
INTARA-BONDONANO-MBFL	BFL Mini 100 W	– 3321
INTARA-BONDONANO-BBS	BBS 70 W	– 3318
INTARA-BONDONANO-BBS	BBS 150 W	– 3319

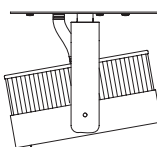
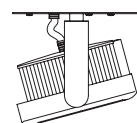

INTARA-ECONDO NANO

INTARA-ECONDOBASICNANO-MBFL	BFL Mini 50 W	– 3320
INTARA-ECONDOBASICNANO-MBFL	BFL Mini 100 W	– 3321
INTARA-ECONDOBASICNANO-BBS	BBS 70 W	– 3318
INTARA-ECONDOBASICNANO-BBS	BBS 150 W	– 3319

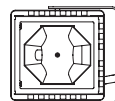

INTARA-ECONDOBWNANO-MBFL	BFL Mini 100 W	– 3321
INTARA-ECONDOBWNANO-BBS	BBS 70 W	– 3318
INTARA-ECONDOBWNANO-BBS	BBS 150 W	– 3319

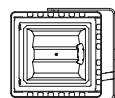

INTARA-ECONDOWWNANO-MBFL	BFL Mini 50 W	– 3320
INTARA-ECONDOWWNANO-MBFL	BFL Mini 100 W	– 3321
INTARA-ECONDOWWNANO-BBS	BBS 70 W	– 3318
INTARA-ECONDOWWNANO-BBS	BBS 150 W	– 3319

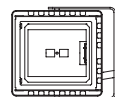

INTARA-ECONDOWALLNANO-MBFL	BFL Mini 50 W	– 3320
INTARA-ECONDOWALLNANO-MBFL	BFL Mini 100 W	– 3321
INTARA-ECONDOWALLNANO-BBS	BBS 70 W	– 3318
INTARA-ECONDOWALLNANO-BBS	BBS 150 W	– 3319

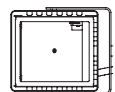

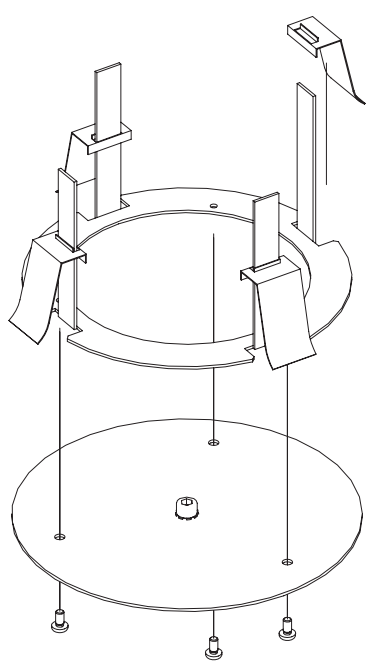
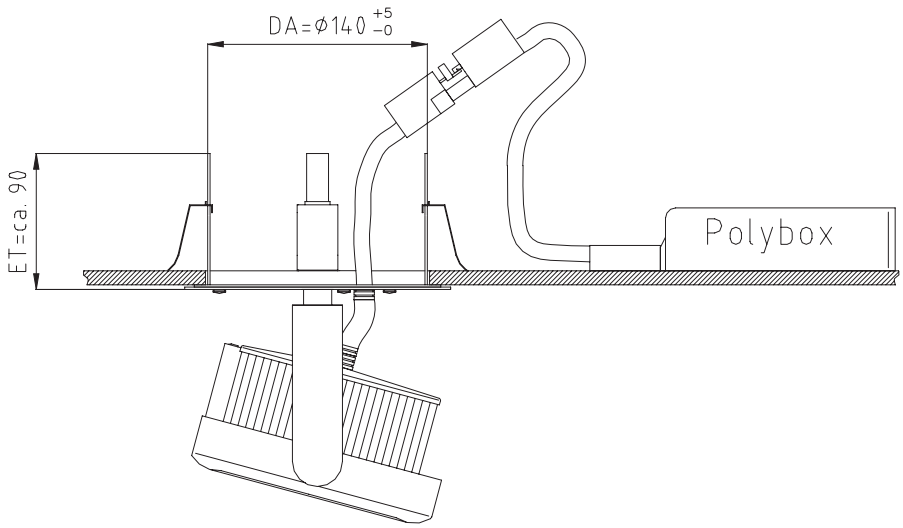

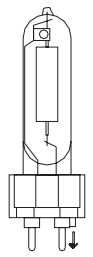
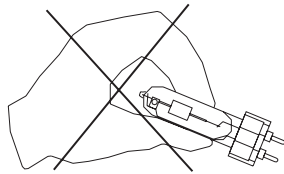

BFL Mini

INTARA-ARONDO NANO

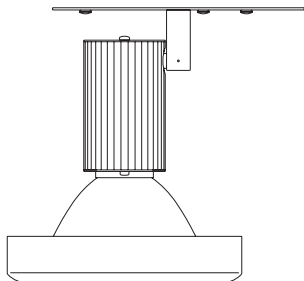

INTARA-BONDO NANO

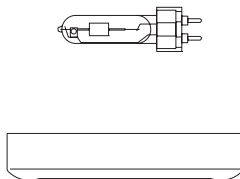
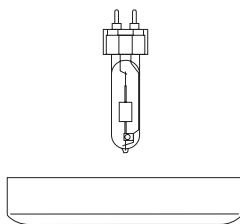
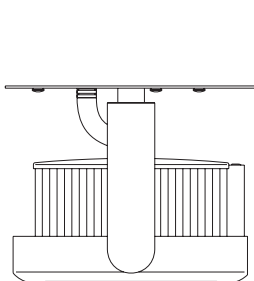

INTARA-ECONDO NANO

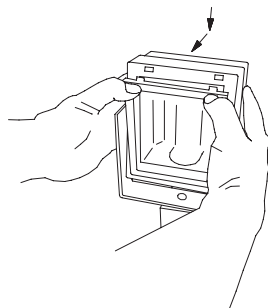
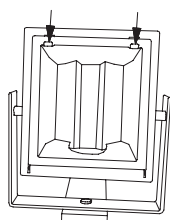

INTARA-ECONDO NANO



INTARA-ECONDO NANO per Riflettore Batwing

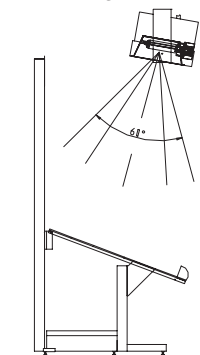
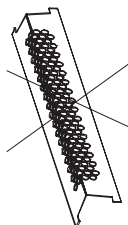
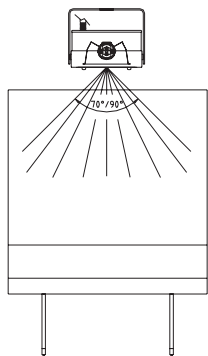

Faro postotrasversalmente rispetto alla superficie da illuminare

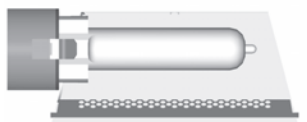
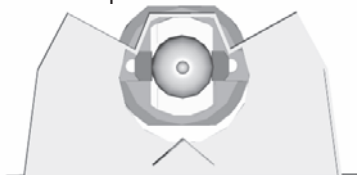

Faro in verticale con fascio luminoso rivolto al corridoio di passaggio e alle scaffalatura

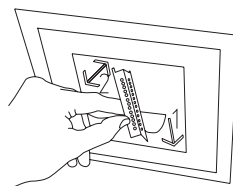
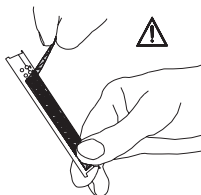
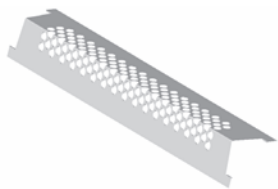
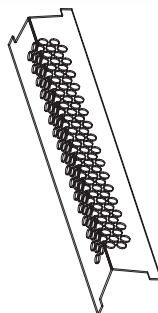
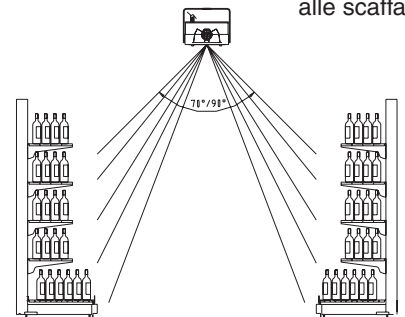

Так как на наши изделия распространяются технические изменения / меры по оптимизации, мы не берем на себя гарантии за то, что все данные соответствуют актуальному состоянию. С вопросами просьба обращаться в наш технический отдел по телефону номер +49 (0) 21 74 - 79 90.

Осуществляя эксплуатацию и монтаж светильников, соблюдать указания по технике безопасности.



Важное указание для светильников с лампочками BFL и BBS: при мигании, полном отказе или очень желтом свете (конец срока службы) немедленно отключить светильник и заменить лампочку.

- Подсоединение разрешается проводить только электрику.
- Проводя монтаж, соблюдать местные предписания.
- Светильники прошли электромонтаж и готовы к подсоединению:
- VDE 0711
- класс защиты I (подключение защитного провода), IP 20
- Соблюдать сведения, приведенные на приборе Polybox и на светильнике.
- В процессе эксплуатации лампочка, светильник и прибор Polybox нагреваются.
- Не покрывать изоляционным материалом светильник и прибор Polybox.
- Не ставить друг на друга приборы Polybox.
- Высокое напряжение на стороне выхода Polybox; опасность для жизни.
- Если провода прибора Polybox повреждены, необходимо заменить прибор Polybox.
- Подсоединение приборов Polybox со стороны сети:
KVG (BFL 35 Вт, 50 Вт, 100 Вт, BBS 35 Вт, 70 Вт, 150 Вт): 230 В +6% -10%, 50 Гц EVG:
220-240 В, 50/60 Гц
- В одной цепи тока (с предохранителем В16А) разрешается эксплуатировать не более:
- BFL 35 Вт, 50 Вт, 100 Вт (KVG) 10 светильников
- BFL Mini 50 Вт (EVG) 24 светильников
- BFL Mini 100 Вт (EVG) 14 светильников
- BBS 35 / 70 Вт KVG 10 светильников / EVG 14 светильников
- BBS 150 Вт KVG 7 светильников / EVG 6 светильников
- BBS 250 Вт EVG 9 светильников
- Заменять лампочки только тогда, когда светильник отключен от сети.
- При монтаже или ремонте светильника отключать цепь тока.
- Соблюдать указания по безопасности, приложенные к лампе.
- Спустя прибл. 3 - 5 минуты лампочка достигает своего полного светового тока.
- После отключения или отказа сети лампочке требуется время для охлаждения, прежде чем она опять зажжется. Для охлаждения отсоединять светильник от сети.
- EVG отключается при тепловой перегрузке, отказе лампы и в конце срока службы лампы. Перед повторным вводом светильника в эксплуатацию необходимо отсоединить EVG от сетевого напряжения. Это правило распространяется и на замену ламп.
- Соблюдать допустимую нагрузку на перекрытие.
- Не удалять или изменять распорки на светильнике.
- Поврежденные провода светильника разрешается заменять только на провода, поставленные заводом-изготовителем.
- Подсоединять только к подходящим предвключаемым приборам с лампами достаточной мощности.
- Эксплуатировать светильники BFL Mini (50/100 Вт) только с электронным предвключаемым прибором (EVG).
- Вывести из эксплуатации светильники BBS с поврежденным или разбитым стеклом до тех пор, пока не будет заменено стекло. Лампа может лопнуть.
- Расстояние до облучаемой поверхности (наклейка в рефлекторе):
- 0,3 м для BFL 35 / 50 / 100 Вт
- 0,5 м для BBS 35 / 70 Вт
- 1,0 м для BBS 150 Вт / 250 Вт
- Использовать только допущенные для светильника лампочки. Соблюдать наклейку в рефлекторе или фирменную табличку с параметрами.
- Указание для 3-фазного режима эксплуатации:
до эксплуатации и во время нее обеспечить, чтобы нейтральный провод был надлежащим образом подсоединен ко всем светильникам EVG.
- Не размещать ничего на светильниках, световых трубках и несущих системах, например, ценники, декоративные элементы.
- KVG: обычный предвключаемый прибор – EVG: электронный предвключаемый прибор

Инструкция по монтажу и эксплуатации INTARA-ARONDO NANO – INTARA-BONDO NANO – INTARA-ECONDO NANO

Источник света

Арт. №

INTARA-ARONDO NANO

INTARA-ARONDO NANO-MBFL	BFL Mini 50 ВтТ – 3320
INTARA-ARONDO NANO-MBFL	BFL Mini 100 ВтТ – 3321
INTARA-ARONDO NANO-BBS	BBS 70 ВтТ – 3318
INTARA-ARONDO NANO-BBS	BBS 150 ВтТ – 3319

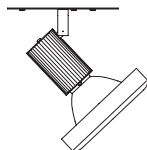

INTARA-BONDO NANO

INTARA-BONDO NANO-MBFL	BFL Mini 50 ВтТ – 3320
INTARA-BONDO NANO-MBFL	BFL Mini 100 ВтТ – 3321
INTARA-BONDO NANO-BBS	BBS 70 ВтТ – 3318
INTARA-BONDO NANO-BBS	BBS 150 ВтТ – 3319

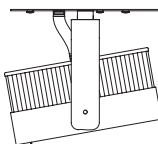
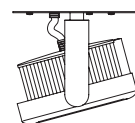

INTARA-ECONDO NANO

INTARA-ECONDO BASIC NANO-MBFL	BFL Mini 50 ВтТ – 3320
INTARA-ECONDO BASIC NANO-MBFL	BFL Mini 100 ВтТ – 3321
INTARA-ECONDO BASIC NANO-BBS	BBS 70 ВтТ – 3318
INTARA-ECONDO BASIC NANO-BBS	BBS 150 ВтТ – 3319

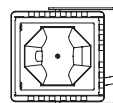

INTARA-ECONDO BWNANO-MBFL	BFL Mini 100 ВтТ – 3321
INTARA-ECONDO BWNANO-BBS	BBS 70 ВтТ – 3318
INTARA-ECONDO BWNANO-BBS	BBS 150 ВтТ – 3319

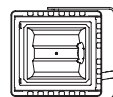

INTARA-ECONDO WWNANO-MBFL	BFL Mini 50 ВтТ – 3320
INTARA-ECONDO WWNANO-MBFL	BFL Mini 100 ВтТ – 3321
INTARA-ECONDO WWNANO-BBS	BBS 70 ВтТ – 3318
INTARA-ECONDO WWNANO-BBS	BBS 150 ВтТ – 3319

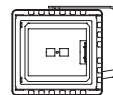

INTARA-ECONDO WALL NANO-MBFL	BFL Mini 50 ВтТ – 3320
INTARA-ECONDO WALL NANO-MBFL	BFL Mini 100 ВтТ – 3321
INTARA-ECONDO WALL NANO-BBS	BBS 70 ВтТ – 3318
INTARA-ECONDO WALL NANO-BBS	BBS 150 ВтТ – 3319

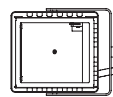

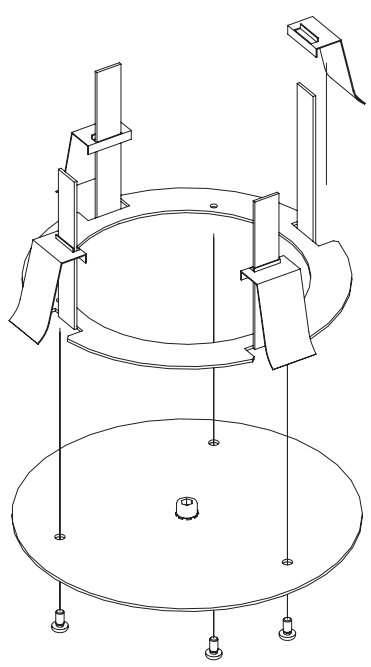
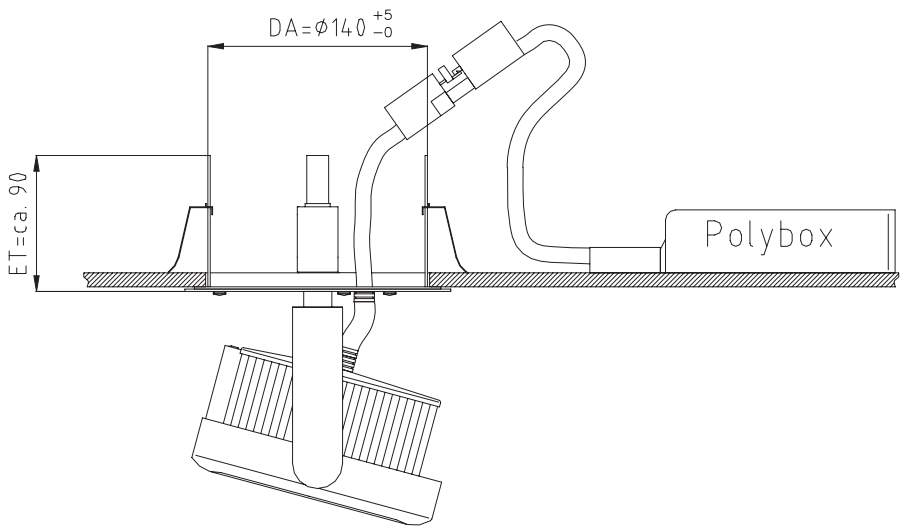

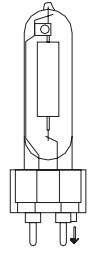
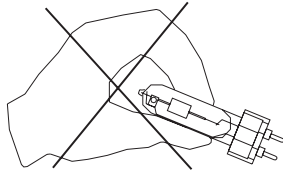

BFL Mini

INTARA-ARONDO NANO

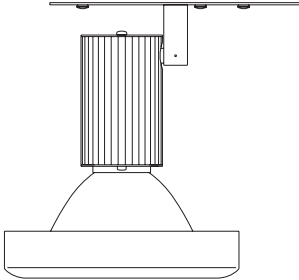

INTARA-BONDO NANO

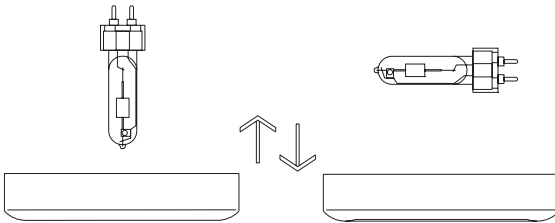
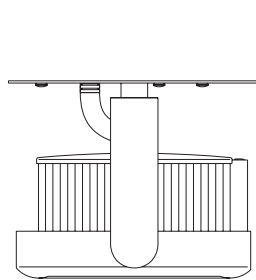

INTARA-ECONDO NANO

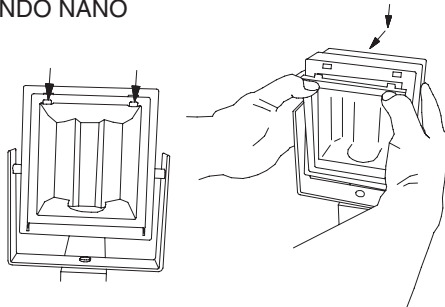

INTARA-ECONDO NANO



INTARA-ECONDO NANO Светильники с ж-образными рефлекторами

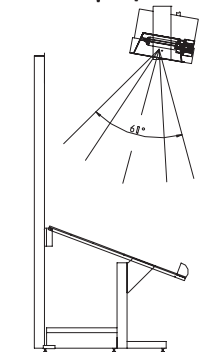
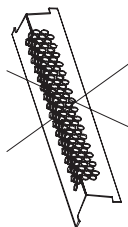
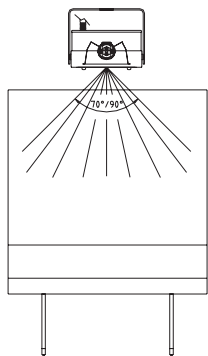

Лампа с размещением поперек к освещаемой поверхности



Лампа с размещением вдоль направления коридоров и полок

